



Feed-Thru Bushing



Features & Benefits

- For RG6 dual or quad-shield cable
- Single configuration available in black or clear
- Dual configuration available in black
- Beveled design ensures firm fit
- Seals wall openings to prevent water mitigation
- Damage-free design secures and protects RG6 cable through wall entry
- Provides clean cable installations sealing roughly drilled holes
- Durable UV-stabilized impact-resistant High-Density Polyethylene construction
- Install & Operation Temp: -40°F (-40°C) to 176°F (80°C)
- Packaging: Bag of 100

Applications

These UV-stabilized, impact resistant feed-thru bushings secure and protect RG6 cable while enabling entry through wall openings in residential or commercial environments.

Description / Specifications

These feed-thru bushings provide a clean cable installation for RG6 dual or quad-shield coax cable and are available in a single or a dual configuration. These wall bushings are composed of a UV-stabilized High-Density Polyethylene.

Technical Illustration

Description	Feed-Thru Bushing	
Packaging	Bag of 100	
Single Black Item Number	Single Clear Item Number	Dual Black Item Number
XACCM-01419	XACCM-01420	XACCM-01421

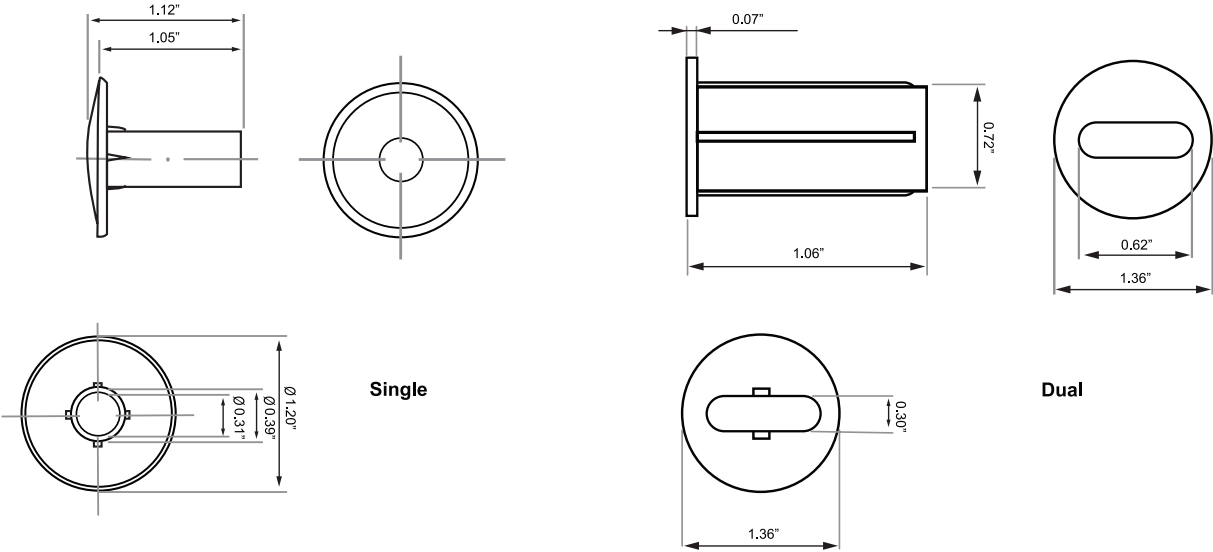

TECHNICAL SHEETS ARE SUBJECT TO CHANGE WITHOUT NOTICE.

REV.20230601.2