



Top Mount Double Fan, 150 CFM



Description

This double fan can be easily installed in the top panel of Vericom AV and High density Wall Mount Cabinets to keep equipment running cool. Designed for flexibility, it can also be mounted inside an enclosure with 19" mounting rails to provide additional front to back airflow.

Technical Drawing

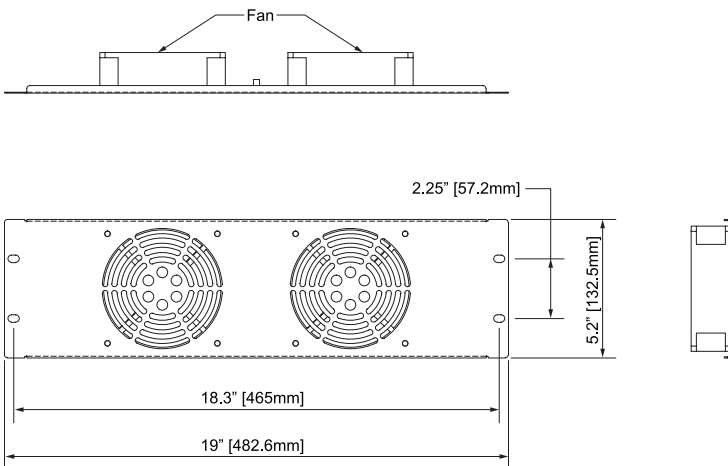

Product Specifications

- Product Type:** Electric Fan
- Impeller Material:** PBT Reinforced Plastic
- Terminals:** 0.02"
- Dimensions (HxWxD):** 5.2" x 19" x 1.8"
- Motor:** Shaded Pole Induction Motor
- Bearing System:** Sleeve
- Cord Length:** 6 ft (*Detachable*)
- Operating Temperature:** -10°C ~ 70°C
- Voltage:** Varies By Item #
- Frequency:** 50 / 60 Hz
- Current:** 0.48 Amps
- Power:** 10 / 9 Watts
- Speed:** 2100 / 2400 RPM
- Noise:** 80 dBA
- Airflow:** 150 CFM
- Static Pressure:** 3.1 / 4.1 (mmH<sup>2</sup>O)
- Weight:** 4 lbs
- Quantity Per Package:** 1

Ordering Information

Description	
Top Mount Double Fan, 150 CFM	
Item #	Max Voltage
RAVFNT2	110V
RAVFNT2-C14	220V