

TOP VIEW

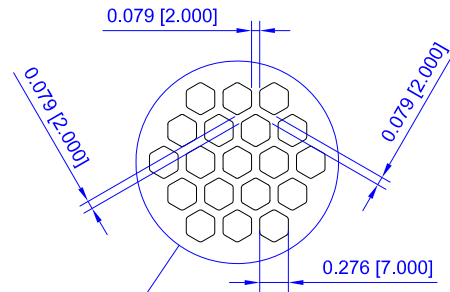

COMPLIANCE	ANSI/EIA RS-310D IEC60297-2 DIN41494; Part 1 DIN41494; Part 7 UL 2416
LOADING CAPACITY	3,000 lbs static load

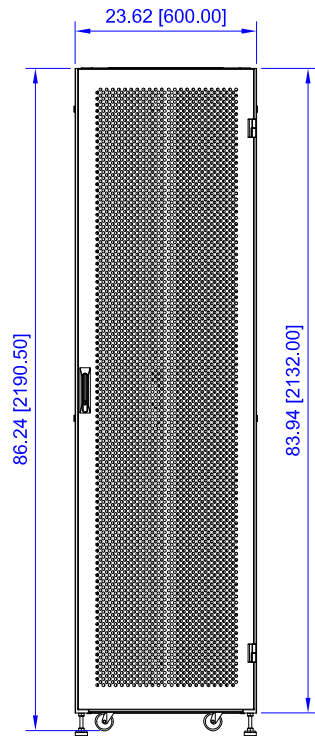
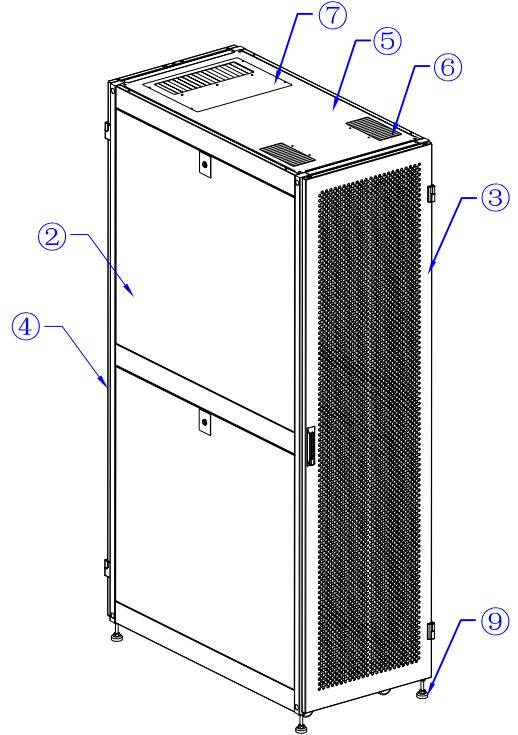

FRONT VIEW

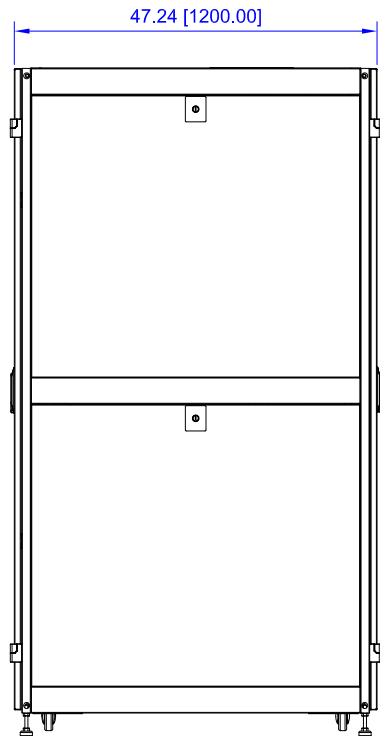

SIDE VIEW

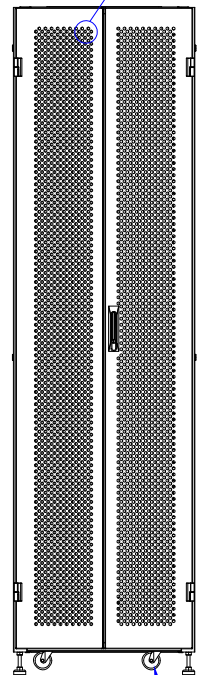

BACK VIEW

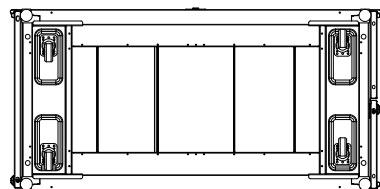

BOTTOM VIEW

12	2	PDU Lacing Panels	Steel	18 gauge
11	4	Cage Hole Mounting Rails	Steel	14 gauge
10	4	2.5" Dia. Casters		
9	4	Adjustable Levelers		
8	2	Adjustable Bottom Panels	Steel	18 gauge
7	1	12.75" x 17" Removable Panel w/Brush	Steel	18 gauge
6	2	Brush Panel Cable Entry		
5	1	Top	Steel	18 gauge
4	1	Split Panel Mesh Rear Door (standard)	Steel	18 gauge
3	1	Full Panel Mesh Front Door (standard)	Steel	18 gauge
2	4	Removable Side Panels	Steel	16 gauge
1	N/A	Cabinet Frame	Steel	18 gauge
NO	QTY	NAME	MATERIAL	THICKNESS

ITEM NO. **VC5-6245-ABS1A** 

DESCRIPTION **45U x 48"D SERVER CABINET**

DATE	SCALE	SHEET	REV
11/29/23	none	1 of 2	2

All dimensions in inches [mm]

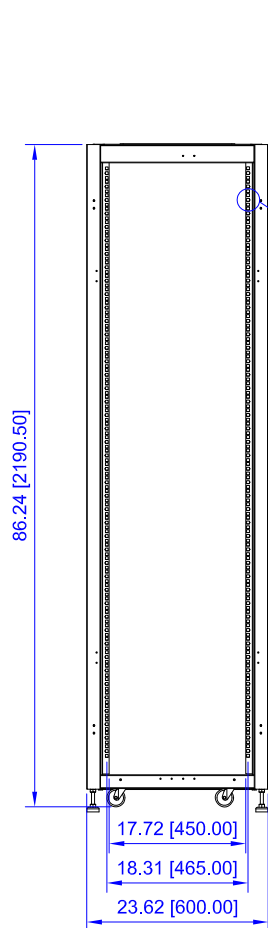

FRONT VIEW
(NO DOOR)

3/8 SQUARE
CAGE HOLES

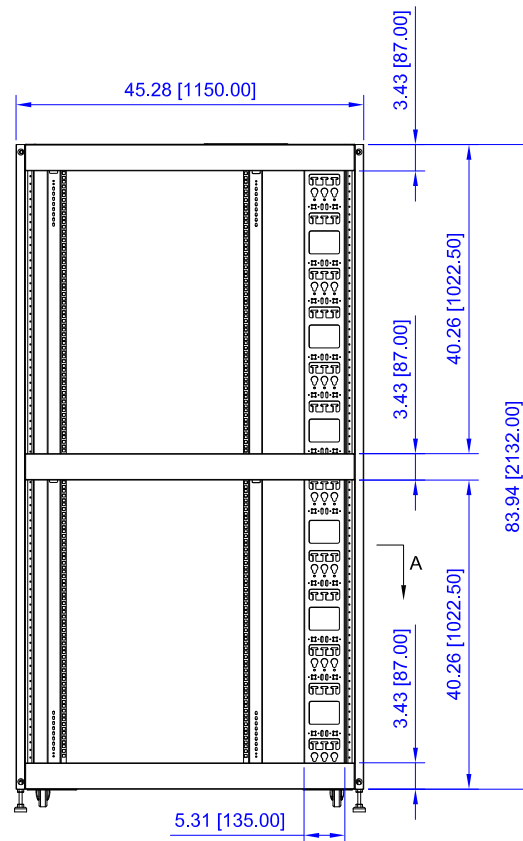

SIDE VIEW
(NO SIDE PANELS)

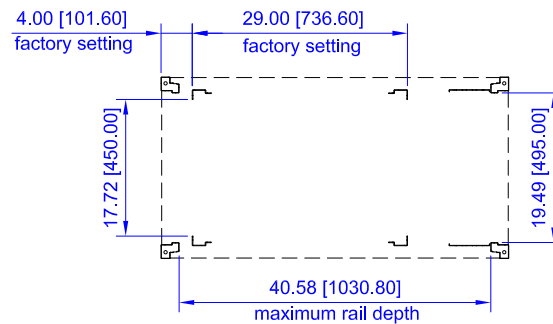

SECTION A-A

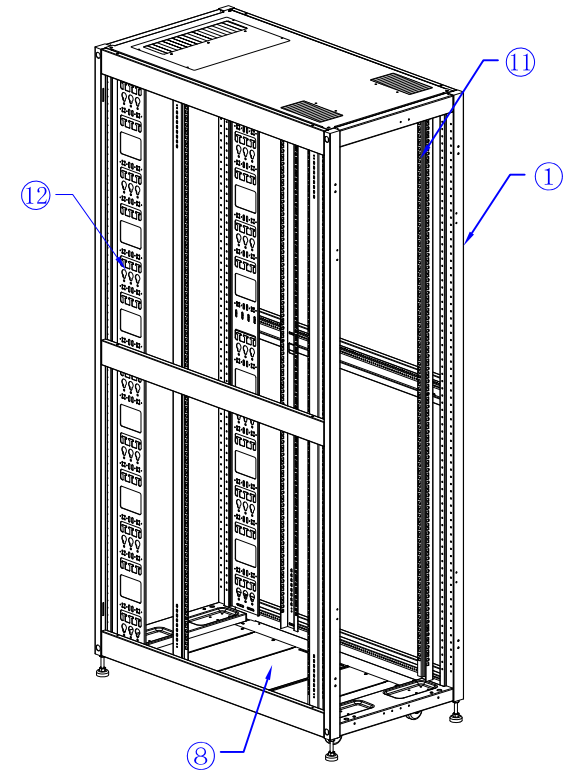

All dimensions in inches [mm]

ITEM NO.	VC5-6245-ABS1A		VERICOM [®]	
DESCRIPTION	45U x 48"D SERVER CABINET			
DATE	SCALE	SHEET	REV	
11/29/23	none	2 of 2	2	