

COMPLIANCE	ANSI/EIA RS-310D IEC60297-2 DIN41494; Part 1 DIN41494; Part 7
LOADING CAPACITY	3,000 lbs static load

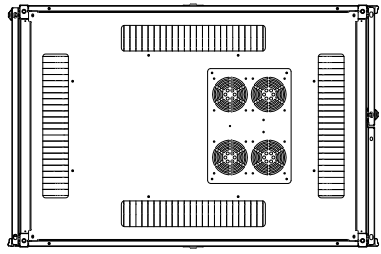

TOP VIEW

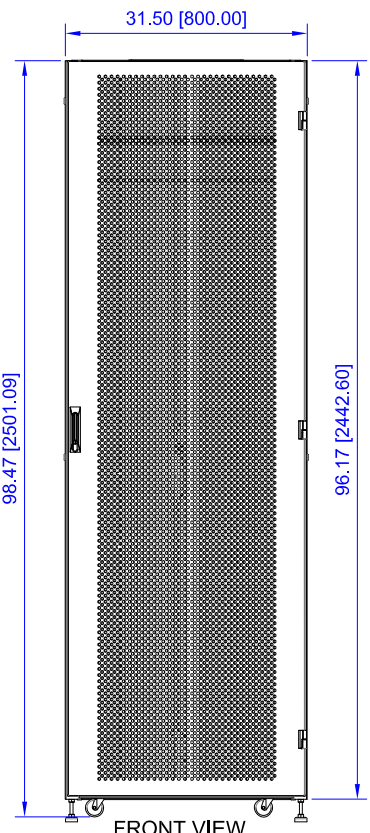
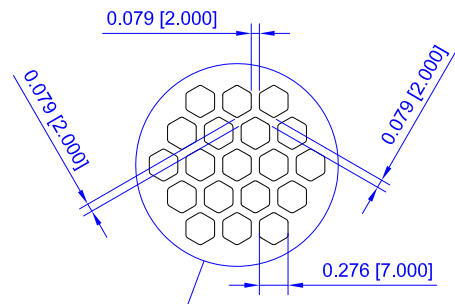

FRONT VIEW

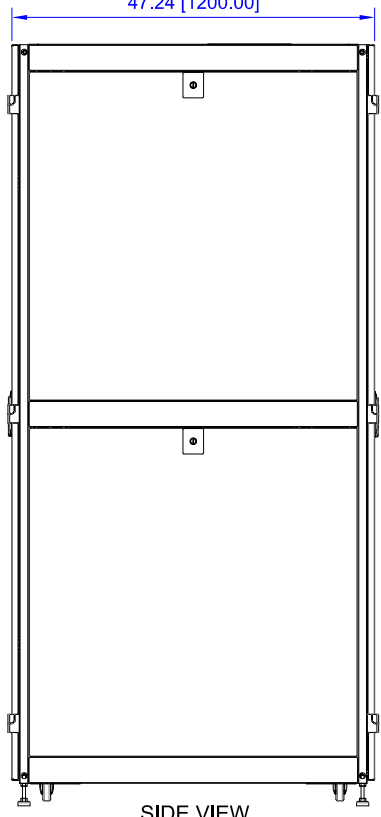

SIDE VIEW

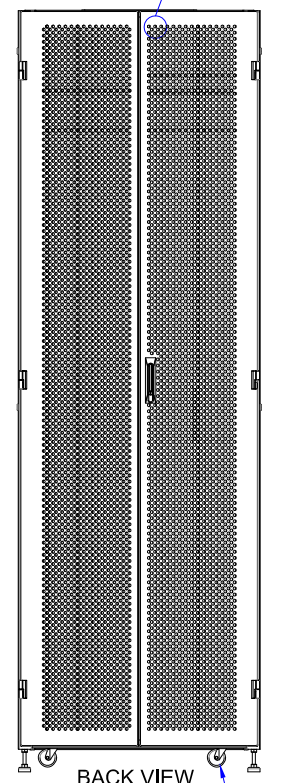

BACK VIEW

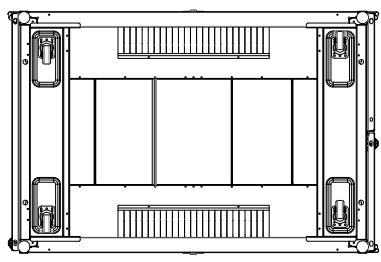

BOTTOM VIEW

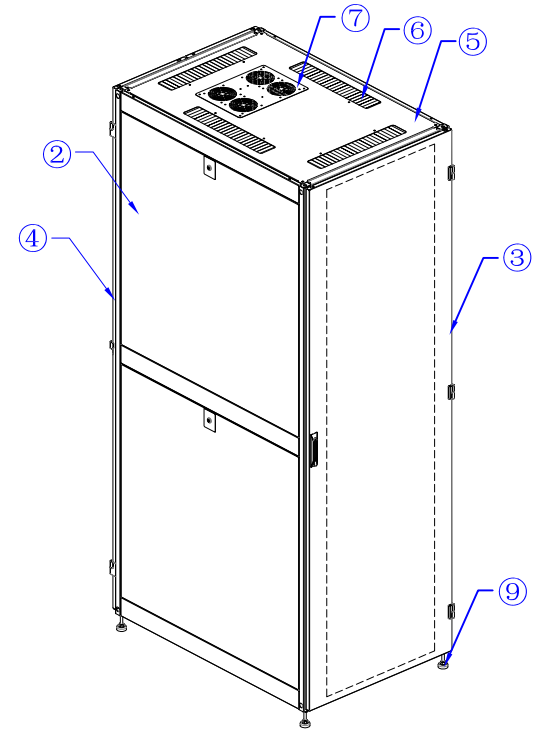

NO	QTY	NAME	MATERIAL	THICKNESS
13	2	Cable Management Trough	Steel	18 gauge
12	2	PDU Lacing Panels	Steel	18 gauge
11	4	Cage Hole Mounting Rails	Steel	14 gauge
10	4	2.5" Dia. Casters		
9	4	Adjustable Levelers		
8	2	Adjustable Bottom Panels	Steel	18 gauge
7	1	Removable Fan Panel	Steel	18 gauge
6	6	Brush Panel Cable Entry		
5	1	Top	Steel	18 gauge
4	1	Split Panel Mesh Rear Door (standard)	Steel	18 gauge
3	1	Full Panel Mesh Front Door (standard)	Steel	18 gauge
2	4	Removable Side Panels	Steel	16 gauge
1	N/A	Cabinet Frame	Steel	18 gauge

ITEM NO.		VC5-8252-ABV1A		VERICOM	
DESCRIPTION					
Network Cabinet, 52U x 31.5"W x 48"D					
DATE	SCALE	SHEET	REV		
05/12/20	none	1 of 2	1		

All dimensions in inches [mm]

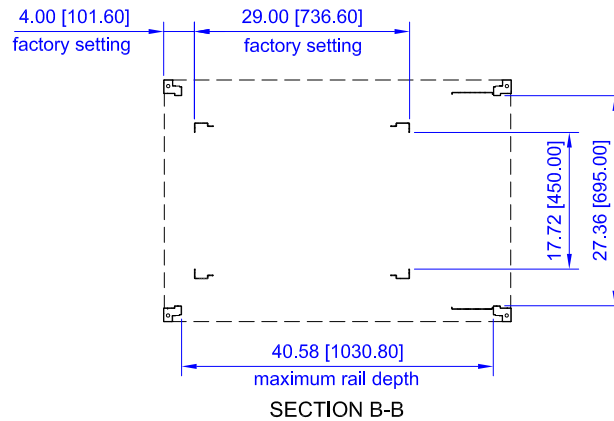
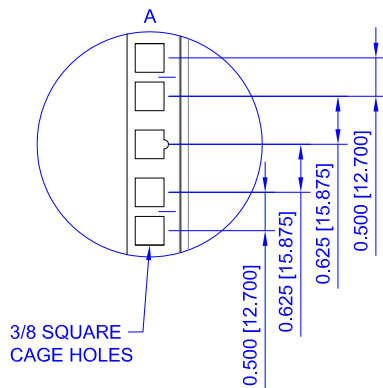
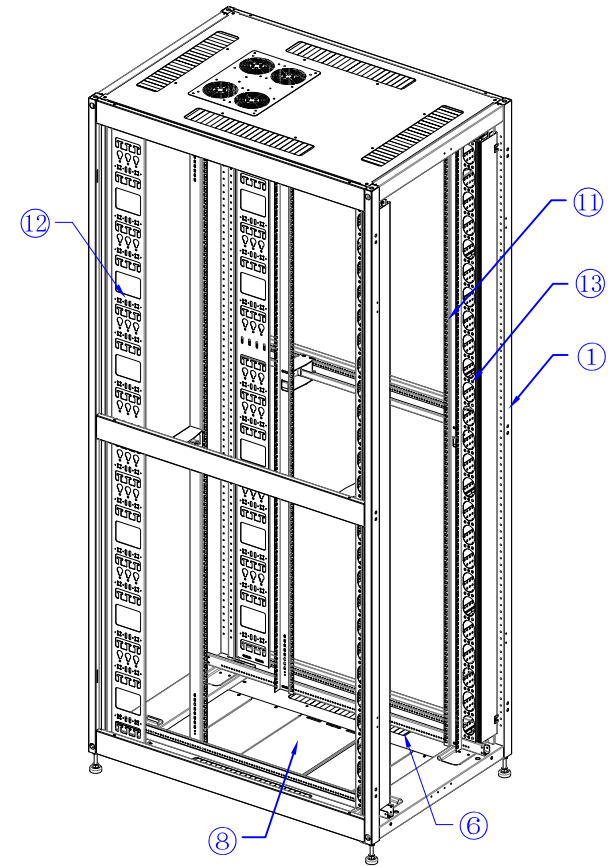
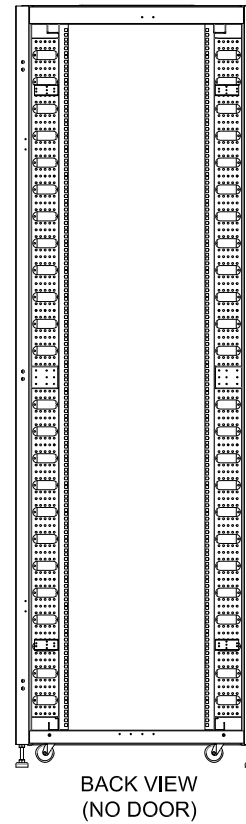
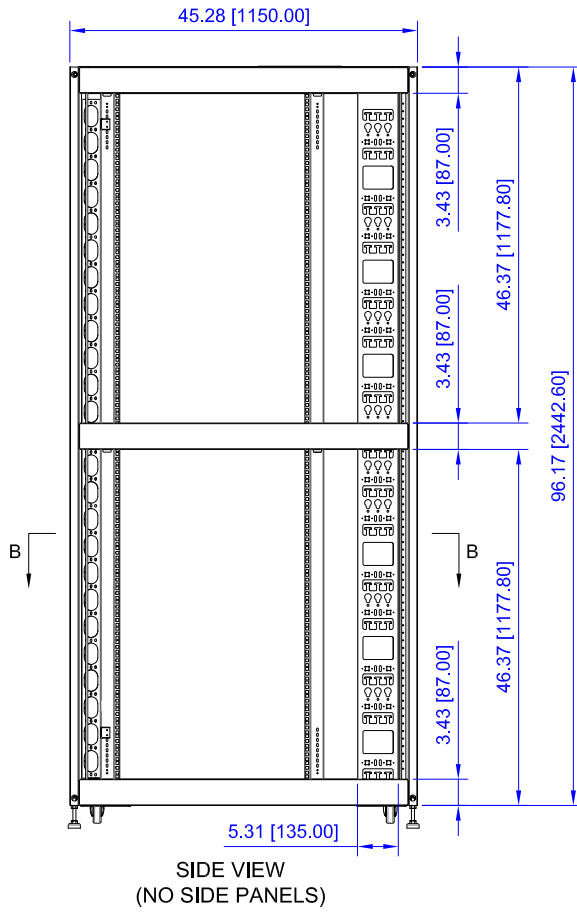
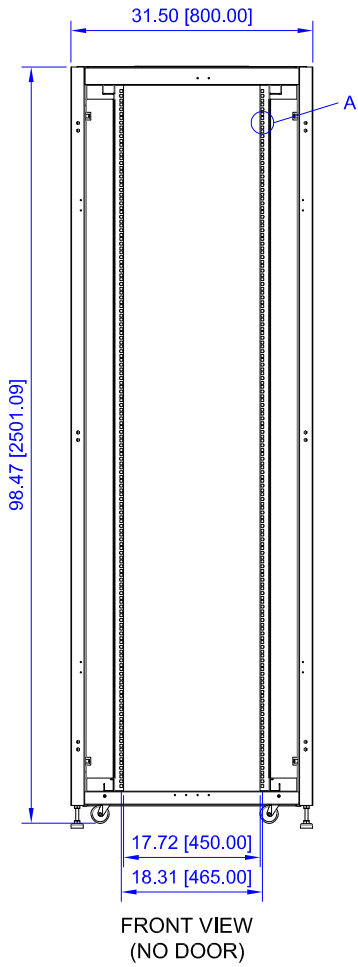

All dimensions in inches [mm]

ITEM NO.	VC5-8252-ABV1A		VERICOM	
DESCRIPTION	Network Cabinet, 52U x 31.5"W x 48"D			
DATE	SCALE	SHEET	REV	
05/12/20	none	2 of 2	1	