

COMPLIANCE	ANSI/EIA RS-310D IEC60297-2 DIN41494; Part 1 DIN41494; Part 7 UL 2416 1 st Ed, NWIN
LOADING CAPACITY	3,000 lbs static load

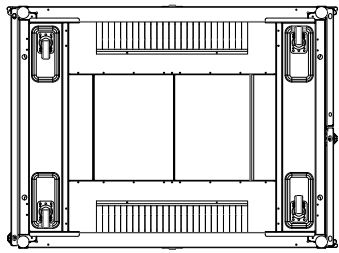
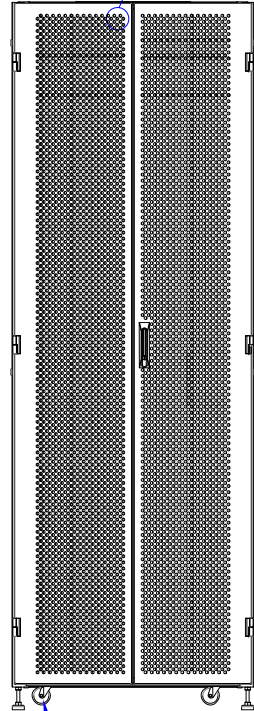
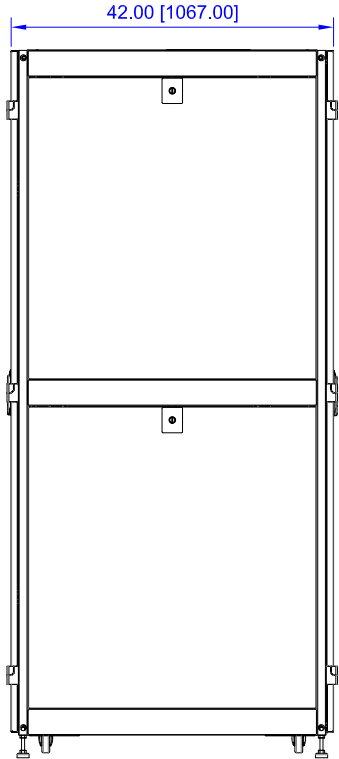
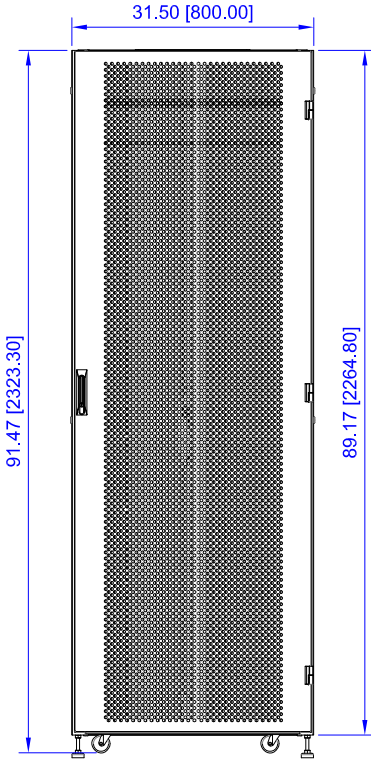
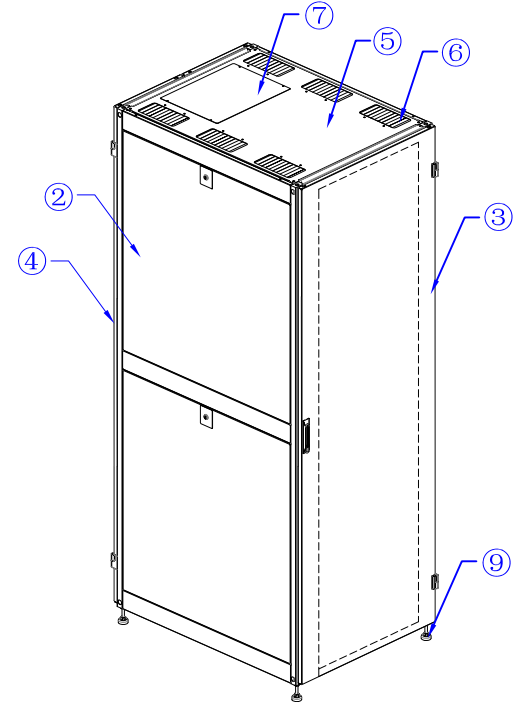
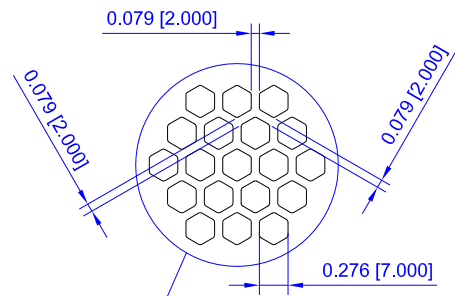
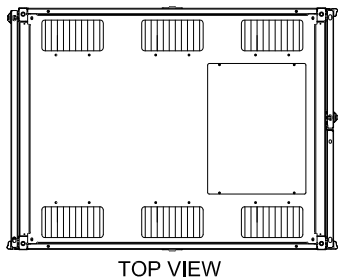

13	2	Cable Management Trough	Steel	18 gauge
12	2	PDU Lacing Panels	Steel	18 gauge
11	4	Cage Hole Mounting Rails	Steel	14 gauge
10	4	2.5" Dia. Casters		
9	4	Adjustable Levelers		
8	2	Adjustable Bottom Panels	Steel	18 gauge
7	1	12.75" x 17" Removable Solid Panel	Steel	18 gauge
6	6	4" x 8" Brush Panel Cable Entry		
5	1	Top	Steel	18 gauge
4	1	Split Panel Mesh Rear Door (standard)	Steel	18 gauge
3	1	Full Panel Mesh Front Door (standard)	Steel	18 gauge
2	4	Removable Side Panels	Steel	16 gauge
1	N/A	Cabinet Frame	Steel	18 gauge
NO	QTY	NAME	MATERIAL	THICKNESS

ITEM NO. **VC5-8A48-ABS1A** **VERICOM**[®]

DESCRIPTION
Network Cabinet, 48U x 31.5"W x 42"D (Black)

DATE	SCALE	SHEET	REV
06/21/22	none	1 of 2	1

All dimensions in inches [mm]

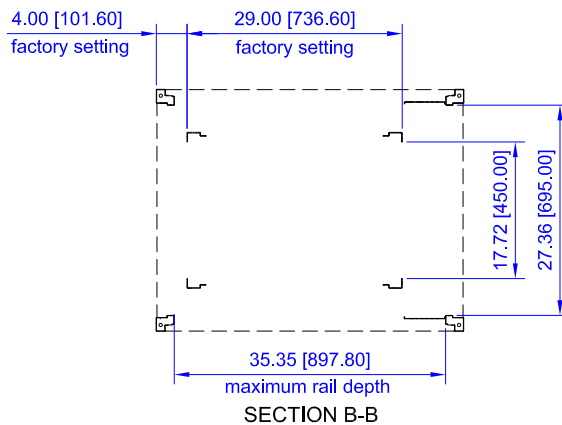
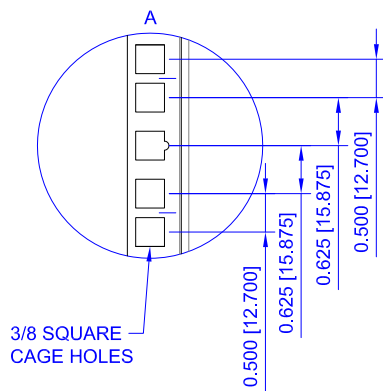
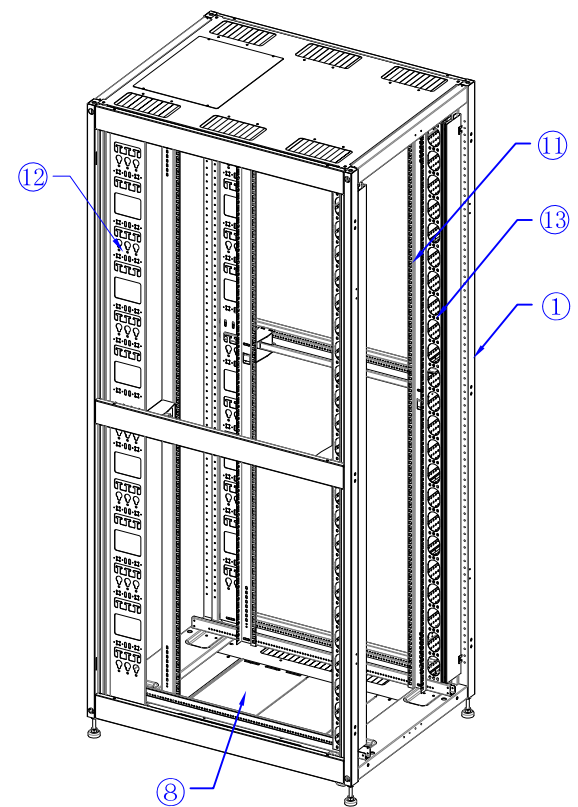
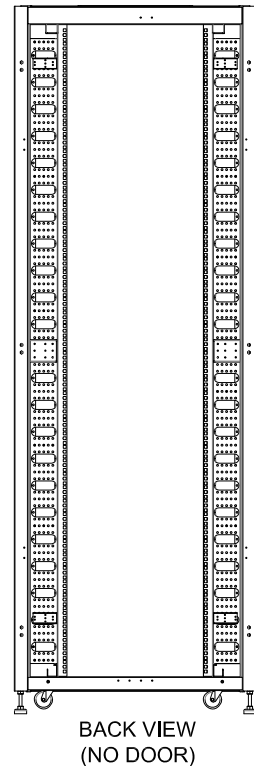
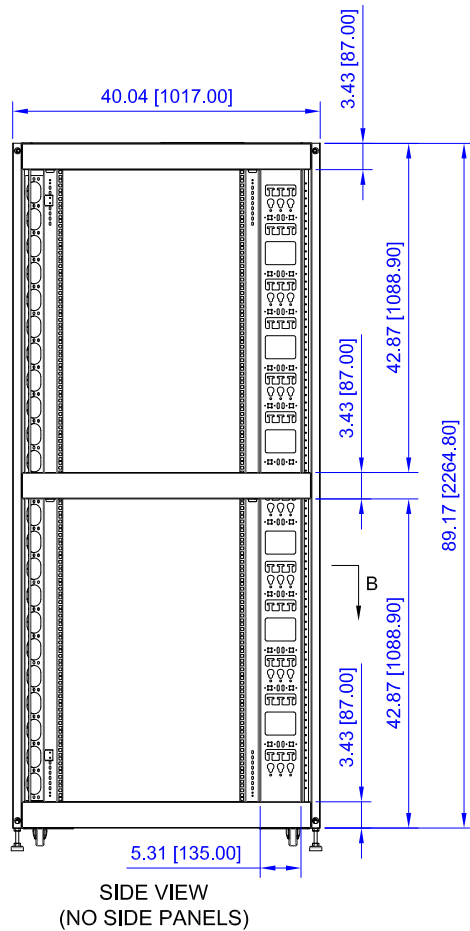
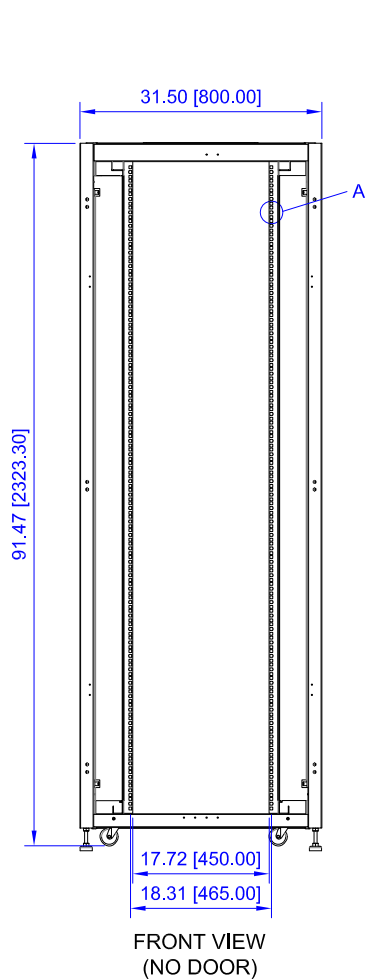

All dimensions in inches [mm]

ITEM NO.	VC5-8A48-ABS1A		VERICOM®	
DESCRIPTION	Network Cabinet, 48U x 31.5"W x 42"D (Black)			
DATE	SCALE	SHEET	REV	
06/21/22	none	2 of 2	1	