

COMPLIANCE	ANSI/EIA RS-310D IEC60297-2 DIN41494; Part 1 DIN41494; Part 7
LOADING CAPACITY	100 lbs

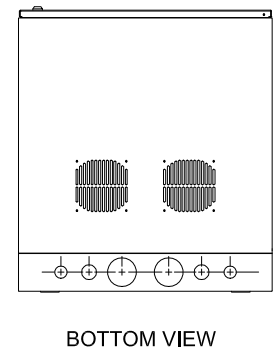
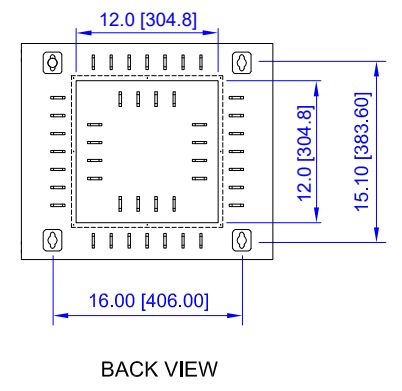
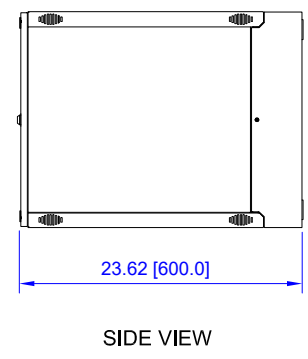
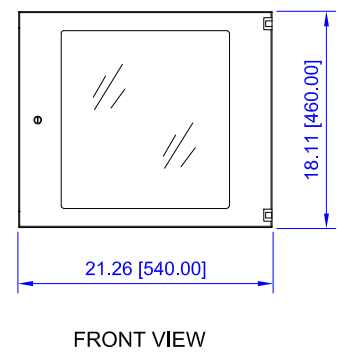
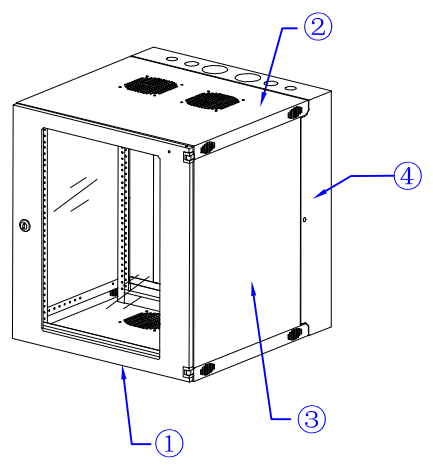
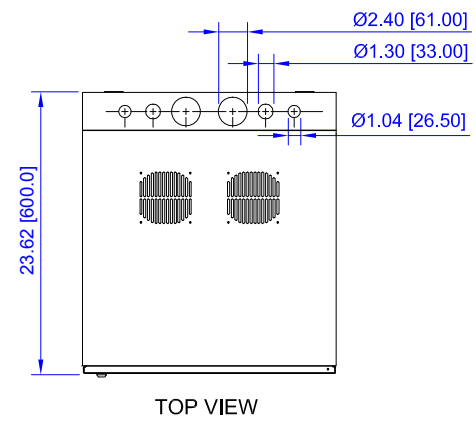

4	1	Rear Door	Steel	19 gauge
3	2	Side Panel	Steel	19 gauge
2	2	Top And Bottom	Steel	19 gauge
1	1	Front Door	Steel with Acrylic Window	19 gauge
NO	QTY	NAME	MATERIAL	THICKNESS

ITEM NO.		VW1-6091*		<b>VERICOM</b> <sup>®</sup>
DESCRIPTION				
<b>9U DOUBLE HINGE WALL CABINET</b>				
DATE	SCALE	SHEET	REV	
05/05/20	none	1 of 1	1	

\*VW1-6091 replaces RWCDH09

All dimensions in inches [mm]