



VW8 Series Wall Mount Cabinet



Description

At 18" depth, our VW8 Series Wall Mount Cabinets are ideal solutions for small installations where space is limited and requirements for equipment storage is minimal.

These compact yet durable cabinets ship flat packed to minimize freight, are easy to assemble and install, and can support up to 132 lbs.

Benefits

Security & Protection

- Lockable doors and side panels prevent unauthorized access to equipment
- Door is grounded to the cabinet frame

Flexibility

- Top panel is stamped for the addition of two fans
- Doors and side panels are removable for convenient access to equipment

Multi-Use

- Adaptable for use in network, security and audio/video installations

Key Features

- Removable and Reversible Locking Front Door with 180° Swing (Available in Steel Mesh or Tempered Glass)
- Top and bottom panel each have a knock-out type cable entry holes
- Adjustable mounting rails can accommodate a wide range of equipment depths



VW8 Series Wall Mount Cabinet

Technical Illustration

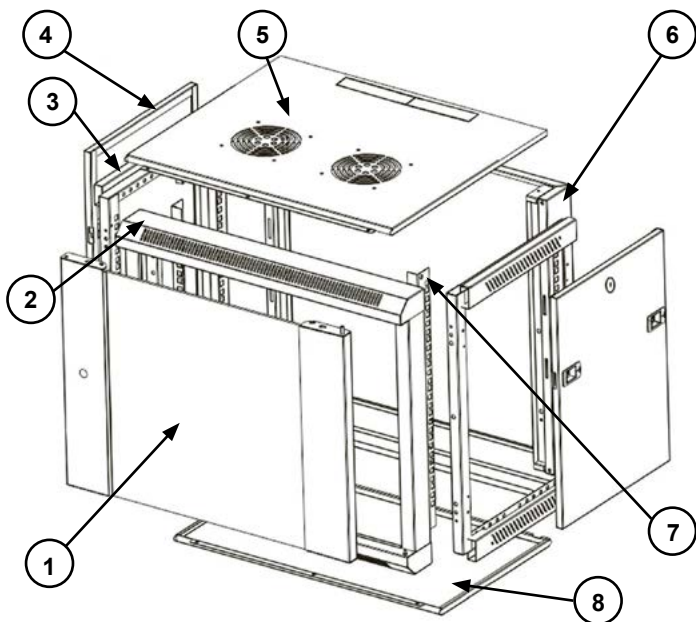

Product Specifications

- Product Type:** Fixed Wall Mount Cabinet
- Frame Material:** 19 Gauge Cold Rolled Steel (1.0mm)
- Finish:** Black Powder Coat
- Dimensions (WxDxH):** 22.4" x 17.7" x (see below)
- Rack Unit Quantity:** 6U, 9U, and 12U
- Front Door:** Removable and Reversible Locking Front Door with 180° Swing (Available in Steel Mesh or Tempered Glass)
- Rear Panel:** Wall Mounting Keyholes Spaced 16.0" Apart
- Side Panels:** Full Height, Lockable, and Removable
- Top Panel:** Optional Fans and Knock-Out Type Cable Entry Holes
- Bottom Panel:** Knock-Out Type Cable Entry Holes
- Equipment Support:** (2) Mounting Rails, 1.75" RU Spacing 19" W, EIA-310-D Universal Hole Spacing
- Grounding:** 14 AWG Ground Wire Connects Door To Cabinet Frame
- Load Capacity:** 132 lbs.
- Included Accessories:** (10) 10-32 Mounting Screws with (20) Washers, (3) Keys, (1) Grounding Wire Kit
- Compliance & Standards:** RoHS, ANSI/EIA RS-310D, IEC60297-2, DIN41494: Part 1, DIN41494: Part 7

Main Part

S/N	Name	Quantity	Material	Surface
1	Front Door	1	19 ga. Cold Rolled Steel	Powder Coated
2	Front Frame	1	19 ga. Cold Rolled Steel	Powder Coated
3	Side Frames	2	19 ga. Cold Rolled Steel	Powder Coated
4	Side Panels	2	19 ga. Cold Rolled Steel	Powder Coated
5	Top Panel	1	19 ga. Cold Rolled Steel	Powder Coated
6	Back Frame	1	19 ga. Cold Rolled Steel	Powder Coated
7	Rails	2	18 ga. Cold Rolled Steel	Powder Coated
8	Bottom Panel	1	19 ga. Cold Rolled Steel	Powder Coated



VW8 Series Wall Mount Cabinet

Ordering Information

Description	VW8 Series Wall Mount Cabinet		
Item Number	Door Type	Rack Units	Dimensions (HxWxD)
VW8-4061G	Tempered Glass Front Door	6U	14.6" H x 22.4" W x 17.7" D
VW8-4091G	Tempered Glass Front Door	9U	19.7" H x 22.4" W x 17.7" D
VW8-4121G	Tempered Glass Front Door	12U	25.0" H x 22.4" W x 17.7" D
VW8-4121M	Steel Mesh Front Door	12U	25.0" H x 22.4" W x 17.7" D

Technical Drawing

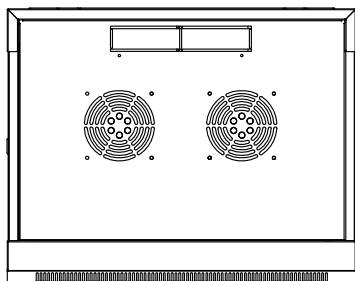

TOP

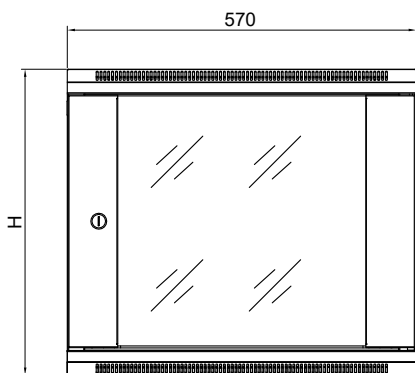

FRONT

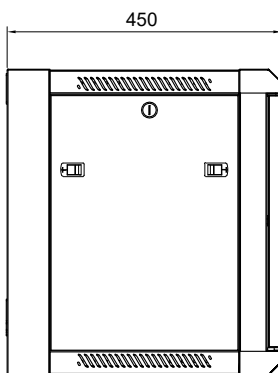

SIDE

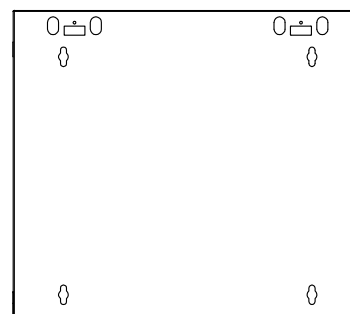

BACK

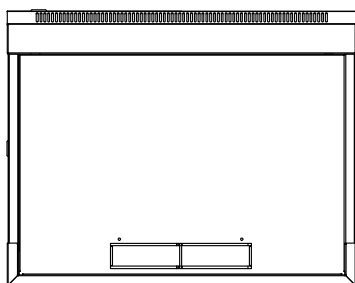

BOTTOM

TECHNICAL SHEETS ARE SUBJECT TO CHANGE WITHOUT NOTICE.

REV.20241030.6